



Project Proposal On

"An AI enabled low Cost mechanized manufacturing of leather products Hub to empower SC community"

Submitted to

Division :SEED

Programme or Scheme : STI Hub for SC Community

Submitted by

Project Investigator:

Dr. T Subha mastan Rao

CMR TECHNICAL CAMPUS HYDERABAD-Hyderabad

Objectives

- i. To protect Traditional knowledge and skills of artisans belongs to SC community living in china munagala village
- ii. Building and Integration of state of art technology for improving traditional leather product manufacturing
- iii. To establish Automated Common service Centre for product expansion and Training

Iv To promote entrepreneurship culture by enabling forward linkages

V. To integrate Ecommerce Technology to sell the produced products globally.

Methodology

In these days advanced machinery available to manufacture leather sandals, shoe, belts, bags, wallets both men and women with raw materials like goat leather, paper boar and lining cloths the products made through machinery are high in quality and attracting customers through out the globe so we are planned to introduce these machineries into their traditional work .Definitely it will help them to produce high quality products with reduced effort.

A.Leather quality detection In this field assessing the quality of the raw material is essential before manufacturing the product. So far people are identifying quality of the leather by looking through their eyes, but majority of the cases they are unable to identify minute defected regions on the leather, finally product made with that leather getting rejected. To solve this problem we are introducing a Deep Learning technique to automatically detect defected regions. In this approach we are going to build a CNN and it is trained with various kinds of leathers which are labeled as good, defected after the training model can able to classify good leather and defected leather. The hardware used in this phase is a CC camera and a lamp through camera leather image captured and is provided as input to the model then model detects whether that piece of leather is good or defected. With this approach leather products will never get rejected due to quality issues.

B.Leather Cutting Machine

Traditionally leather cutting was done manually using knife and other instruments,in this process the quality of the cutting is very poor. Apart from quality the speed of the work is very low. Even cutting is the very essential phase for manufacturing any kind of leather product. So in this project we are manufacturing a hydraulic based leather cutter which will cut the leather based on the die shapes. In this we are using composite material for manufacturing leaver and external material which will come in low cost and durable when compared to existing cutting machines. The motors inside the machine convert electrical power into hydraulic force. Through this machine large number of shapes with high quality can produce in less time and effort , for shapes in our campus we are having advanced 3D printing labs there we are going to prepare different dies used in manufacturing different products.

Even this die manufacturing also automated using a software robot. It is build using robotic process automation implemented on UIPath software which help to create dies automatically without manual intervention..

C.Sole cutting Machine Traditionally people are using various traditional methods in order to shape a sole as per the product requirement.

To avoid difficulty in traditional work we have introduced a machine which can able to cut the sole as per the given dimensions even machine can able to cut many shapes in asingle shot in different widths. After cutting upper layer is pasted to sole and by using ball press we can attach sole and leather. This machine can able to hold different kinds of blades such as stright edge blades,cross edge blades etc.

D.Leather sewing machine Traditionally leather workers having practice of sewing products with their own hands. Definitely it is highly time consuming process due to this workers can able to produce very less number of products. In this project we are proposing a machine with clutch motor , servo motor optimized in power consumption high cycling speed and strong needle support. This machine can able to sew all types of leather products with high speed and accuracy by compensating existing problems like Fabric or threads are bunching at the start or ends of seams, Machine skipping stitches etc

E.Leather Embossing

Beatification is very important for selling any product, in traditional days workers unable to print design, names, logos on leather products in this proposal we are introducing machinery called ball press. By using this machine we can print customized logos on leather products shown below. This machine optimized with low power liver to reduce power leaver so that effort required to apply the manual force also reduced. This machine can work with dies of different dimensions all the designs printed on the die can be transferred to leather by using ball press.

F.Leather polish detection Polishing the leather also one of the major task in leather product manufacturing in this process we are introducing AI based solution which will automatically stops when polishing was reached to optimal level using deep learning. This model saves time and quality of the product when compare to manual observation of the polishing condition.

Expected Deliverables

A common Training Center can establish for RD, Training and production

This project will provide an opportunity to upgrade the skill of SC community people in the manufacturing of Leather products.

Existing manual process to produce leather products are replaced with machinery through which quality products can produce comparatively in large scale.

Establishment of micro production units.

Direct marketing relations will be established using government and NGO organizations both in online offline.

Part 2: Particulars of Investigators

Principal Investigator:

1. Name:	Dr. T Subha mastan Rao
Gender:	Male
Date of Birth:	29/08/1984
Designation :	Assoc Professor
Department:	CSE
Institute/University:	CMR TECHNICAL CAMPUS HYDERABAD
State:	Telangana
District:	Hyderabad
City/Place:	Hyderabad
Address:	CMR Technical Campus, Kandlakoya, Medchal Road, Hyderabad
Pin:	501401
Communication Email:	mastan1061@gmail.com
Alternate Email:	mastan299@gmail.com
Mobile:	9000404339
Phone:	
Fax:	
Category:	SC

Co-Investigator:

1. Name:	Dr. DMANEIAH
-----------------	--------------

Gender: Male
Date of Birth: 01/07/1976
Designation : PROFESSOR
Department: MECHANICAL
Institute/University: C M R TECHNICAL CAMPUS
State: Telangana
District: Hyderabad
City/Place: BACHUPALLY
Address: PLAT NO: G1,PRAGATHI NAGAR,BACPALLI
Pin: 500090
Communication Email: hod.mech@cmrtc.ac.in
Alternate Email:
Mobile: 9246874863
Phone:
Fax:
Category: SC

2. Name: Dr. S VIJAYA BHASKAR REDDY
Gender: Male
Date of Birth: 01/03/1965
Designation : PROFESSOR
Department: CIVIL
Institute/University: C M R TECHNICAL CAMPUS
State: Andhra Pradesh
District: Kadapa
City/Place: PULIVENDULA
Address: NAGARI GUTTA,PULIVENDULA,KADAPA,AP

Pin: 516390
Communication Email: cbhasker.civil@cmrtc.ac.in
Alternate Email: vbsgen06@gmail.com
Mobile: 9885841297
Phone:
Fax:
Category: General

3. Name: Mr. J RATNA BABU
Gender: Male
Date of Birth: 25/04/1986
Designation : ASST PROFESSOR
Department: ECE
Institute/University: C M R TECHNICAL CAMPUS
State: Andhra Pradesh
District: Prakasam
City/Place: PARCHURU
Address: 7-101-2,HARIJANAVADA,PARCHURU,PRAKASAM
Pin: 523169
Communication Email: ratanbabu.ece@cmrtc.ac.in
Alternate Email: ratan.bab@gmail.com
Mobile: 8328586839
Phone:
Fax:
Category: SC

Suggested Refrees:

1. Name: DrAChandrasekhar Rao

Mobile: 9471191414

Designation : Asst Professor

Email: acsrao@iitism.ac.in

Institute/University: IIT DHANABD

Address: IIT DHANBAD

Academic Area: Electronics,Computers and Communication Engineering,

Application Area: Entrepreneurship and Innovation,

State: Jharkhand

District: Dhanbad

City: Dhanbad

Address: Dr. A. C. S. Rao, Assistant Professor, Department of Computer Science and Engineering, Indian Institute of Technology (Indian School of Mines), Dhanbad, Jharkhand, 826004.

Pin Code:

Part 4: Financial Details

Financial Details:

A. Non - Recurring

A1. Non-Recurring (e.g. equipments, accessories etc.)

S.	Equipments	Qty.	Justification	1 Year	2 Year	3 Year	Total
1 .	Ball press	2	used to apply press to connect two materials or print design	60000	0	0	60000
2 .	Class room Furniture and office furniture	1	training and marketing purpose	100000	0	0	100000
3 .	Common Skilling Center	1	place and construction	1000000	0	0	1000000
4 .	Electrification and installation	1	Electrification at common service center	80000	0	0	80000
5 .	fabrication cost	1	machinery making cost	155000	0	0	155000
6 .	fabrication cost	1	production line expenditure	0	100000	100000	200000
7 .	Leather quality checking machine	2	it is used to verify quality of the leather before production	75000	0	0	75000
8 .	sewing machine	4	To sew all types of leather products	180000	0	0	180000
9 .	Smart cutting machine	4	used to cut the leather into different shapes	100000	0	0	100000

10.	Sole cutting machine	2	used to cut sole	50000	0	0	50000
11.	Wooden vat for washing, Tools and equipments	1	cleaning	10000	0	0	10000
12.	Zinc block for design Embossing	2	design purpose	28000	0	0	28000
Total				1838000	100000	100000	2038000

A2. Others Non-Recurring : NA

B. Recurring

B.1 Project Staff

S.	Project Staff	No.	Justification	1 Year	2 Year	3 Year	Total
1.	Project Assistant	1	provide assistance in all stages	180000	180000	180000	540000
2.	Project Associate	1	Deal with training and production	264000	264000	264000	792000
3.	Project Scientist	1	take care about technical aspects of the project	360000	360000	360000	1080000
Total				804000	804000	804000	2412000

B.2 Consumable

S.	Items	Qty.	Justification	1 Year	2 Year	3 Year	Total
1.	Buttons	1	used in wallets,bags,belts 1000	10000	10000	10000	30000
2.	D or O rings	1000	used in bags,shoe etc 1000	10000	10000	10000	30000
3.	Decorative fitting	500	used for decoration	20000	20000	20000	60000
4.	Goat leather	1	used to prepare various leather products 3000 sq/ft	180000	180000	180000	540000
5.	Lining cloth	1	Used inside the products 1000mt/year	60000	60000	60000	180000
6.	Silver Polyester Eagle Industrial Threads Cones	100	used for sewing	20000	20000	20000	60000
7.	zips	1	used in bags etc 1000	20000	20000	20000	60000
Total				320000	320000	320000	960000

B.3 Travel

S.	Description	Justification	1 Year	2 Year	3 Year	Total
1.	Project Logistics	different equipment purchase	25000	25000	25000	75000
2.	Review Meeting by DST	transportation and accommodation etc	20000	20000	20000	60000
3.	Field Activities	visit to the field	55000	55000	55000	165000
Total			100000	100000	100000	300000

B.4 Contingency

S.	Description	Justification	1 Year	2 Year	3 Year	Total
1.	Documentation	entire process documents printing costs	15000	15000	15000	45000
2.	Servicetothe equipment	regular maintenance	40000	40000	40000	120000
Total			55000	55000	55000	165000

B.5 Any Other Head

S.	Description	Justification	1 Year	2 Year	3 Year	Total
1.	Training on End Product	final product training	0	0	300000	300000
2.	Orientation and inception of the course	Orientation and inception of the course	20000	0	0	20000
3.	Practice session	Practice session	0	0	150000	150000
4.	Testing Period	Testing Period	0	150000	0	150000
5.	Induction Training	traing to selected people	30000	0	0	30000
6.	Hands on training	training on live production	0	0	250000	250000
Total			50000	150000	700000	900000

B.6 Overhead

S.	Description	Justification	1 Year	2 Year	3 Year	Total
1.	Institutional over heads	usage of labs,seminor halls,discussion rooms etc	150000	150000	150000	450000
Total			150000	150000	150000	450000

Budget Head Summary in (INR)

Budget Head	Year-1	Year-2	Year-3	Total
1- Non-Recurring				
Equipment	1838000	100000	100000	2038000
2- Recurring				
Project Staff	804000	804000	804000	2412000
Travel	100000	100000	100000	300000
Overhead	150000	150000	150000	450000
Contingency	55000	55000	55000	165000
Consumable	320000	320000	320000	960000
Any Other Head	50000	150000	700000	900000
Total	3317000	1679000	2229000	7225000

PFMS Details:

PFMS Unique Code Available: Yes

PFMS Unique Code :

CMRTCPFMS

Part 5: Current Ongoing Project

Current Ongoing Project: NA

List of Uploaded Documents:-

1. Complete Project proposal
2. Biodata
3. Certificate from PI
4. Conflict of interest
5. Endorsement from head of Institute
6. Quotation for Equipments

Government of India
Ministry of Science and Technology
Department of Science and Technology
Science for Equity Empowerment and Development (SEED) Division

FORMAT FOR APPLICATION

SCIENCE TECHNOLOGY AND INNOVATION HUBS

PART I: EXECUTIVE SUMMARY

1. Project Title: **An AI enabled low Cost mechanized manufacturing of leather products Hub to empower SC community**

Science Technology and Innovation Hub in China Munagala village, Konejarla Block, Khammam District, Telangana State.

2. **Name of the Institution & Address: CMR Technical Campus, Kandlakoya (V), Medchal Rd, Hyderabad, Telangana 501401**

3. Details of the Project Team

i. Name of the Principal Investigator: Dr.T.Subha Mastan Rao

ii. Name of Co-Investigator (s): Dr.Maneiah,Dr.Vijaya Bhaskar Reddy, Mr.Ratna Babu

4. Project Area Profile:

(a) Demographic Details China Munagala is a Village in Konijerla Mandal in Khammam District of Telangana State, India. It belongs to Telangana region . Khammam district lies between 16° 45' and 18° 35' of Northern Latitude and 79° 47' and 80° 47' of the Eastern Longitude. Paddy, Cotton, Maize, pulses are the major **crops** during Kharif season and Paddy, Maize, Pulses and Chillies are the major **crops** during Rabi. More than 50% population belongs to SC community, majority of them are skilled in producing leather products.

(b) Socio-economic Status The targeted people are earlier working full time in manufacturing leather products as they are unable to compete with machine made products slowly they are shifting to agriculture still decent number of people are working on leather products on part time basis. Per day they may earn 210/- even agriculture also not good here due to poor water availability, more crop diseases in this area etc.

(c) Target Beneficiaries : Target beneficiaries are SC community people they are around 51% in this area.

5. Nature of the Project (you may tick all the relevant options)

Technology development (new technology, new product/process)	
Adaptive R&D (Location Specific Research & Technology Development including Technology modification/modulation/ optimization, up/down scaling of existing systems, technology adaption/adoption etc)	✓
Technology transfer (field trials, demonstrations & transfer of technology)	✓
Technology dissemination and deployment (Replication of successful models, dissemination of available technology for solution of identified problem)	

6. Give the details/list of technologies

<i>Sl. No.</i>	Technologies (Interventions)	<i>Justification</i>
a.	Artificial Intelligence	We are using AI for testing quality of the leather and finished products
b.	Optimized mechanical machineries	Low cost machinery for sewing, cutting of leather.

7. Importance of the proposed Technologies (Interventions) in the context of current status

In china munagala village from age olds SC artisans are producing leather from animal skin with their traditional skills and knowledge shown in Fig.1. Apart from producing leather they are also producing products from leather such as leather sandals, shoes, belts, bags, knife holders etc. To produce these items they are using traditional tools. So it is really very hard and time consuming process in order to prepare products with hard tools. Even as it is manual process they are unable to produce large in number and getting very low revenues, details are shown in Fig.2, Fig.3 . In this village many skilled people are there in this domain. If we can identify and provide necessary skilling to them on the machinery to improve the process of their traditional work and produce high quality products with less effort and time .Then quality products they can sell in the market with less price when compared to other

competitors and able to earn good profits, so these revenues can change socio economic conditions of these people.



Fig.1 Manual Production of Leather from animal Skin



Fig.2 Manual Production of Leather sandals



Fig.3 Various Leather items produced locally

8. Science &Technology component/Innovativeness/Novelty of the project.

Technology nowadays playing major role in our day to day life when we made field survey in the village based on the data we have collected it is clearly understand that majority of the people in this village from SC community are working on leather item production. Whenever they are not having agriculture work. In existing machinery also having various problems to measure quality of the leather, utilization and smart sewing so We thought of introducing AI enabled machinery to their traditional works then they can able to produce high quality products which will increase the ethnic value in their product.

A. Leather quality detection :

In this project we are planning to build a machine which is capable of detecting leather quality. To achieving that we are planed to implement a Deep learning framework to check the quality of the leather before start producing any products. The prototype of the planed hardware used to implement leather quality detection shown in the Fig.4

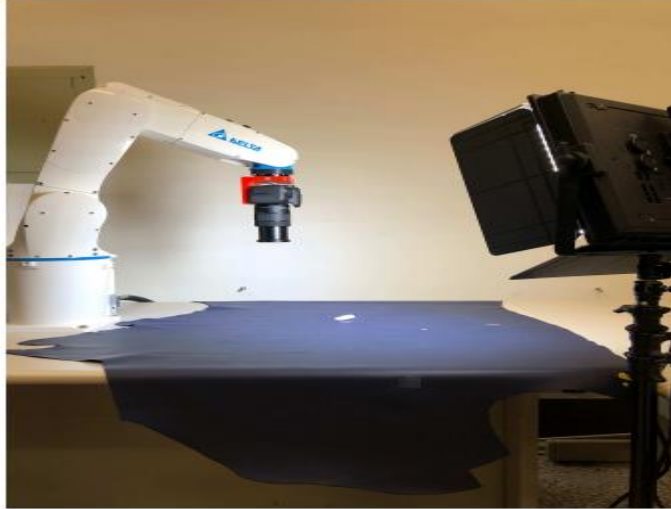

Fig.4. Hardware prototype for leather quality detection

To find defected parts in the leather we are going to build a CNN model , initially it was trained on various leather sheets which are good and defected so that model can understand the patterns of the quality leather and defected leather . once model is build the defected segment in the leather sheet can be identified .

B. Leather Cutting Machine: Traditionally people are using various instruments like knives to cut the leather as per their product requirements. In this approach they are unable to produce more products and the quality of the cutting and shape of the product also vaarying .To solve these problems we are proposing a machine which can able to perform die based cutting through hydrlic pressure generated through electrical power. The motors inside the machine convert electrical power into hydrolic force. Through this machine large number of shapes with high quality can produce in less time and effort . for shapes in our campus we are having advanced 3D printing labs there we are going to prepare different dies used in manufacturing different products the prototype of the machine show in below Fig.5

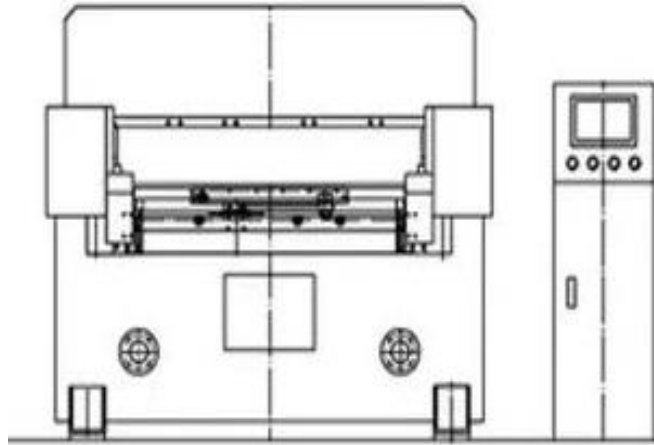

Fig.5. Leather cutting Machine

C. **Sole cutting Machine:** Sole is important material used in many leather products; mostly it covers bottom part of the product. It is thicker than leather for cutting the sole we are proposing a low cost hydraulic machine which works in both manual as well as electrical power to generate hydraulic force. By covering the draw backs in the existing system we are planning to manufacture this machine with composite material to reduce cost and time which intern help these SC workers to produce high quality products in less time these machines definitely add more ethnic value to their traditional works.

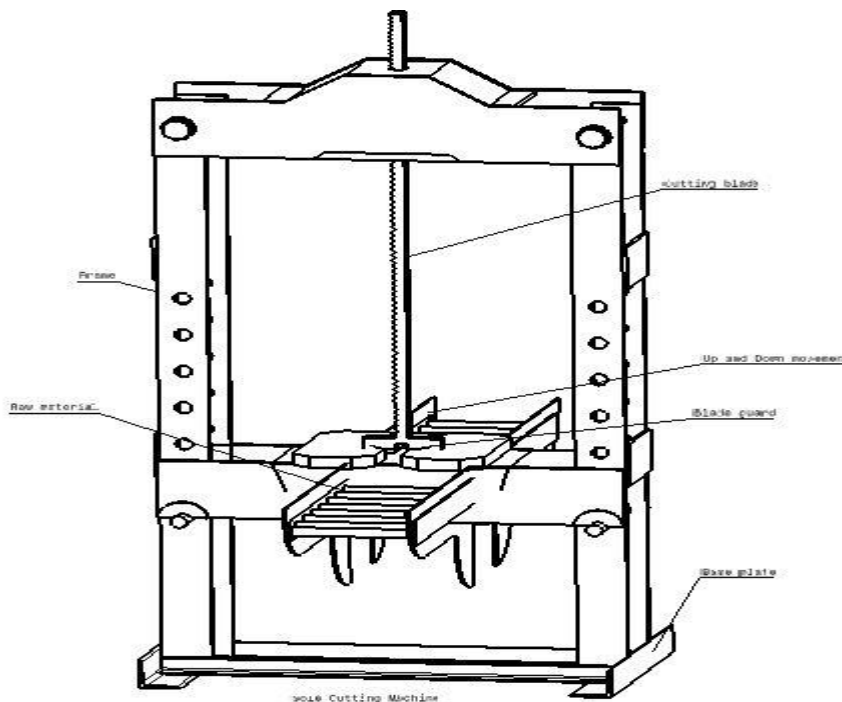

Fig.6. Sole cutting Machine

D. **Leather sewing machine:** sewing is very important phase in manufacturing various leather products such as sandals, shoe, wallets etc. different products required different types of threads for sewing. Traditionally these workers sewing manually with small instruments it is a lot of time consuming process and required more manual power. To solve these problem we are introducing a low cost multiple sewing machine which can be used for multiple product stretching with high speed .

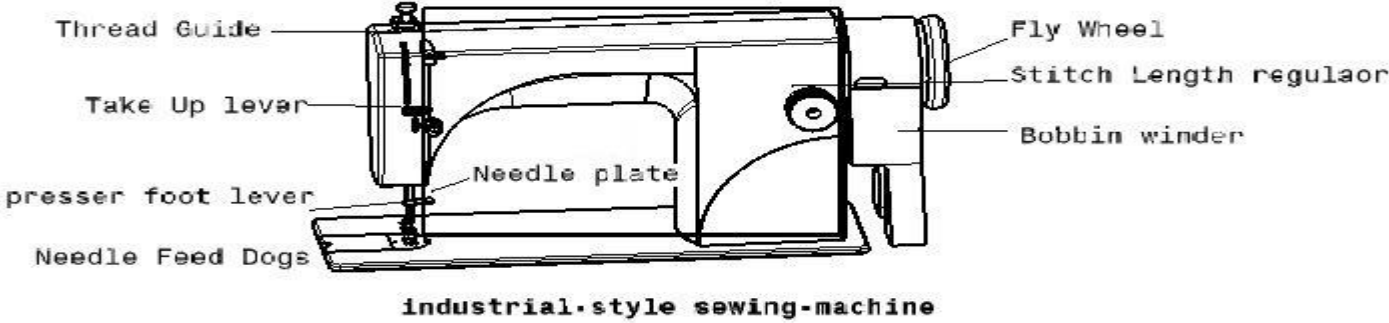

Fig.7 Leather Sewing Machine

E. **Leather embossing machine:** Ball pressing machine is used to print any design on the leather or logos any text that is made through different molds. In traditional work these kind of designs are not there in their work , in order to create more beauty to the products we are introducing a simple mechanical ball press that help to paste two items, designs on the items etc.

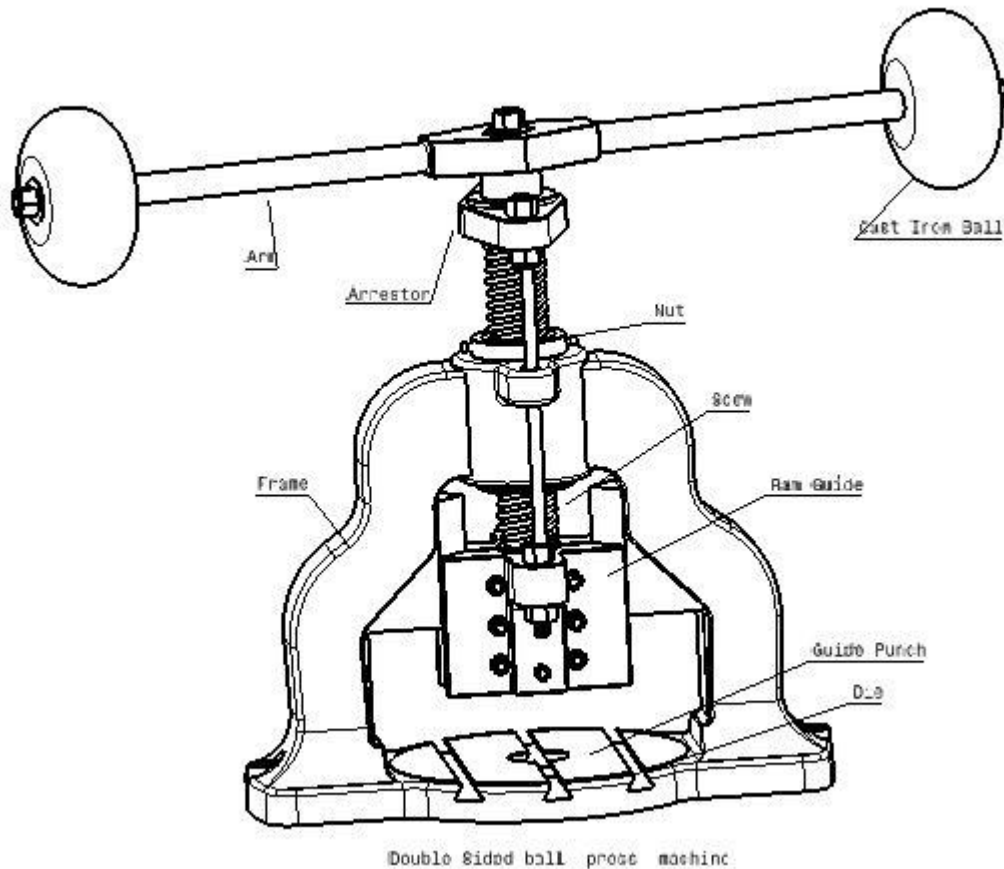

Fig.8. Ball Press

F. **Leather polish detection:** Polishing the leather also one of the major task in leather product manufacturing in this process we are introducing AI based machinery which will automatically stops when polishing was reached to optimal level that saves time and quality of the product when compare to manual observation of the polishing condition.

By using these machines workers can able to produce more quality products when compared to their traditional production. Even these products are having high quality when compared to the products produced using normal machinery so with this high quality they can very easily reaches to the global market.

To achieve this we are planning to establish central skill center in that all the machines are kept and it will function like production unit as well as training center. In this training center we are going to provide hands on training to all the selected candidates in different departments required for production of various identified products. Once training is completed we are planning to help them through government schemes to establish micro industries. The products produced through these micro industries are sold through the a E-commerce site build through our in house team. We will sell all these products through this site. This site is popularized with the support of government, NGO, peer academic institutes, students. So that they can able to sell their products at best price even customer can able to get the products for low cost. This will be like win win situation for both producer and consumer finally these poor SC people can able to get regular income and intern socio economic conditions of this section of people improve.

9. Expected Deliverables:

- A common Training Center can establish for R&D, Training and production
- This project will provide an opportunity to upgrade the skill of SC community people in the manufacturing of Leather products.
- Existing manual process to produce leather products are replaced with machinery through which quality products can produce comparatively in large scale.
- Establishment of micro production units.
- Direct marketing relations will be established using government and NGO organizations both in online & offline.

10. Expected benefits to the target groups/population

- These people can able to produce products with high ethnic value when compared to their traditional work.
- Majority will become entrepreneurs and some of them will get employment in their companies
- Social status of these people also increases as they are regularly working and earn decent income.

- Even those who are not part of this training also can get benefit indirectly through employment provided by these small companies, as purchase capacity of the villagers increases all other dependent sectors also grown.

Education , health, socio economic conditions of these people will definitely improved

11. Please give a brief business plan/enterprise model/sustainability of the project.

In this proposal CMRTC manufacturing low cost machinery to replace traditional tools used in the leather product manufacturing. Once these machineries are manufactured a common facilitating center will be established in that center R&D activities, product manufacturing and training to traditional workers will be done . Those who finished training they are assisted to establish their own micro units for manufacturing leather products with the support of different external agencies. Centrally an E-Commerce site is build to provide global market linkage to all established micro units. Apart from these common facilitation center will produce different products those products also sold through various marketing channels over a period of time the revenues generated will make the project self sustain so it can continuously upgrade with innovative machinery, products. Even the training can extend to many parts of the state in due course.

12. Details of the beneficiaries

Initially this project planed to implement in china munagala village where 100 leather workers are identified tentatively who are belongs to 50 plus families. In phase wise we are planning to extend this service to other villages.

13. Details of Collaborators

<i>Sl. No.</i>	<i>Name and Address of the Collaborators</i>	<i>Purpose</i>
1.	ASHRITHA is a registered NGO(Regd.No.1611/12) having its registered office in #H.No.8-3-132/23 Janardhan Reddy colony, Meerpet, K.V.Ranga reddy,Telangana-500097	Role: Assistance in selection of right people. To motivate the selected SC people for active participation, Coordinating with local authorities,dissertation of information

14. Duration (months): 36

15. Budget Summary:

Recurring Cost : 51,87,000

Non-Recurring cost : 20,38,000

Sl. No	Item	Budget			
		1 st Year	2 nd Year	3 rd Year	Total
A	RECURRING				
1	Manpower	8,04,000	8,04,000	8,04,000	24,12,000
2	Consumables	3,20,000	3,20,000	3,20,000	9,60,000
3	Travel	80,000	80,000	80,000	2,40,000
4	Training Programs	3,00,000	3,00,000	3,00,000	9,00,000
5	Review Meeting by DST	20,000	20,000	20,000	60,000
6	Contingencies	55,000	55,000	55,000	1,65,000
7	Institutional Overheads	1,50,000	1,50,000	1,50,000	4,50,000
B	NON RECURRING				
1	Permanent Equipment	6,83,000			6,83,000
2	Fabrication of Equipment	1,55,000	1,00,000	1,00,000	3,55,000
3	Construction Costs	1000000			1000000
TOTAL		35,67,000	18,29,000	18,29,000	72,25,000

16. Details of Principal Investigator, Co Investigators and Affiliation

i. Principal Investigator	
Name	Dr.T.Subha Mastan Rao
Sex and Date of Birth	Male,29-08-1984
Highest Qualification and Expertise	Ph.D
Designation	Assoc Professor
Department	CSE
Institute/University	CMR TECHNICAL CAMPUS
Complete Address with Pin Code	Kandlakoya (V), Medchal Rd, Hyderabad, Telangana 501401
Telephone and Fax Numbers	
Mobile Number	9000404339
E – Mail	mastan1061@gmail.com
ii. Co Investigator	
Name	Dr.D.Maneiah
Sex and Date of Birth	Male ,
Highest Qualification and Expertise	Ph.D
Designation	Professor

Department	Mechanical
Institute/University	CMR Technical Campus
Complete Address with Pin Code	Kandlakoya (V), Medchal Rd, Hyderabad, Telangana 501401
Telephone and Fax Numbers	9247033440
Mobile Number	9246874863
E – Mail	hod.mech@cmrtc.ac.in
ii. Co Investigator	
Name	Dr.S.Vijaya Bhaskar Reddy
Sex and Date of Birth	Male ,Mar 1 st 1965
Highest Qualification and Expertise	Ph.D
Designation	Professor
Department	Civil
Institute/University	CMR Technical Campus
Complete Address with Pin Code	Kandlakoya (V), Medchal Rd, Hyderabad, Telangana 501401
Telephone and Fax Numbers	9247033440
Mobile Number	9885841297
E – Mail	Cbhasker.civil@cmrtc.ac.in
iii. Co Investigator	
Name	Mr.J.Ratna Babu
Sex and Date of Birth	Male,25-04-1986
Highest Qualification and Expertise	M.Tech
Designation	Asst.Professor
Department	ECE
Institute/University	CMR Technical Campus
Complete Address with Pin Code	Kandlakoya (V), Medchal Rd, Hyderabad, Telangana 501401
Telephone and Fax Numbers	9247033440
Mobile Number	8328586839
E – Mail	ratnababu.ece@cmrtc.ac.in

17. Details of ongoing/completed projects of the investigator(s) during the last 5 years

Sl. No.	Name of the project	Reference No	Funding Agency/Division	Cost & Duration	Status
1	International Conference on "Materials Research and Applications-ICMRA-2016"	36/17/105/2018- BRNS/17077 AERB/RDD/ CSRP-2/2016 TSCOST/NS D-16/2015-16	BRNS AERB TSCOST	150000.00	Completed
2	UGC Raman Fellowship	F 5-160/2016 (IC)	UGC	2657844.00	Completed
3	National Conference on Computer, Security, Image Processing, Graphics, Mobility and Analytical (NCCSIGMA-2016)	SB/SS/1184/16-17	SERB DST	100000.00	Completed
4	Metal Oxide Nanocomposites for BTEX Sensor Application	F.No: ECR/2016/00 0534	SERB DST	2860000.00	Completed
5	Context Vector Machine for Thematic Traits in Multimedia Files and Documents	Ref.No.: SR/CSRI/367 /2016 (G)	DST	3773600.00	Ongoing
6	Assessment of R&D Impact on Socio-	DST/NSTMI S/05/227/201	DST	3655960.00	Ongoing

	Economic Status of Rural India	6-17 (G)			
7	Second Expert Committee Meeting Biobliometrics	DST/NSTMI S/04/07/2016-17	DST	1210000.00	Ongoing
8	Prediction of the Air Quality in Road Traffic Air-water samples by Temporal-Spatial Distribution using Foldscope	BT/IN/Indo-US/Foldscope /39/2015	DBT	800000.00	Ongoing
9	Co-doped ZnO thin films of toxic VOC sensing	CSR-IC/MSRSR-21/CRS-229/2017-18/1310	UGC-DAE Consortium for Scientific Research	45000.00	Ongoing
10	For PG Colleges	SR/FST/College-017/2017	DST	4500000.00	Ongoing
11	National Conference on Cyber Security, Image Processing, Graphics, Mobility and Analytical (NCCSIGMA-2K19)	F.No: SSY/2018/001267	SERB DST	100000.00	Ongoing
12	Development of Indium tin Oxide based sensors for enhanced toluene detection	Procs.No: JNTUH/TEQ IP-III/CRS/2019/Physics/01	JNTUH	250000.00	Ongoing

13	Development of WO3 based thin film sensors for medical diagnosis devices	Procs.No: JNTUH/TEQ IP-III/CRS/2019/Physics/03	JNTUH	250000.00	Ongoing
14	Study of stimulating research in Indian University for socio-economic development of India	File No.: NSTMIS/05/252/2017-18	DST		Ongoing
15	International Conference on Advanced Light-weight Materials and Structures	File No: SSY/2019/001286	DST SERB	100000.00	Ongoing

18. Expected Output and Outcomes :

Output Indicators

<i>Sl. No</i>	<i>Indicator</i>
1.	Number of new network programmes initiated
2.	Number of new technologies/ techniques/ tools/ processes developed
3.	Geographical Coverage/Number of beneficiaries/ households
4.	Number of technologies transferred and or deployed in field or commercialized
5.	Number of Reports/Manuals
6.	Number of patents applied/granted
7.	Number of papers published
8.	Number of Common Facility Centres/ Permanent Structures/ Common Resources Created
9.	Number of SHGs/CIGs/TAGs/FPOs formed under the Project
10.	Number of Skill development and Capacity building Programmes Conducted
11.	Number of Awareness and Trainings Programmes conducted
12.	Number of social, mini and microenterprises developed/ established

Outcome Indicators (only indicative)

<i>Sl. No</i>	<i>Indicator</i>
1.	Access to efficient technologies which will build long term assets (Number of HH)
2.	Improved access to basic infrastructure facilities like Energy, Water, Health, Sanitation, Built environment etc (Number of HH)
3.	Improved access to financial institutions and digital infrastructure (Number of HH)
4.	Number of people and/or organizations using common facilities and infrastructure created under the project
5.	Livelihood Diversification (Number of livelihoods options generated)
6.	Backward linkages – Access to stable input resources and/or Access to affordable cost of capital (Number of HH)
7.	Forward linkages – Access to existing or newer linkages and/or Access to last mile supply chains (Number of HH)
8.	Number of skilled manpower (men and women) generated and jobs created
9.	Scientific Capacity Building & Technology Absorption Capacity – Knowledge transfer on best practices and Awareness on best alternatives (Number of people other than the project beneficiaries)
10.	Number of entrepreneurs created, Improvement in entrepreneurship ecosystem
11.	Number of other organizations motivated and mobilized for replication of project outcomes

PART II: TECHNICAL DETAILS OF PROJECT

1. Introduction

(a) China Munagala is a Village in Konijerla Mandal in Khammam District of Telangana State, India. It belongs to Telangana region . Khammam district lies between 16° 45' and 18° 35' of Northern Latitude and 79° 47' and 80° 47' of the Eastern Longitude. Paddy, Cotton, Maize, pulses are the major **crops** during Kharif season and Paddy, Maize, Pulses and Chillies are the major **crops** during Rabi. More than 50% population belongs to SC community, majority of them are skilled in producing leather products.

(b) As per the 2011 census in this village SC/ST population is 51.3% good number people working on manufacturing leather products on part time during rainy seasons and remaining time they are working as agriculture coolies. The average annual income of a male is around 48,000/- and female is 24,000/- most of the people are not having basic amenities like proper house, good food, education for their children's.

(c) In this area **Rancare Industries Ltd** are the leading **Manufacturer** of an extensive array of **UPVC Window, AAC Blocks, UPVC Doors, Nufix Wall Care Putty, Ready Wall Plaster, Nufix Tile Adhesive**, etc apart from this there are no industries in this area

(d) Most of the people are having leather product making as a traditional skill if we can encourage them by providing proper eco system they will produce world class products that will definitely improve their socio economic conditions. Due to lack of proper financial facilities there is no work for them regularly. Even soil also not good they need to depend on rain. Still one hope that is they are highly skilled in making leather products.

(e) Details of the project implementation site/ Location map of the target area (as far as possible should be in the vicinity of the targeted population).

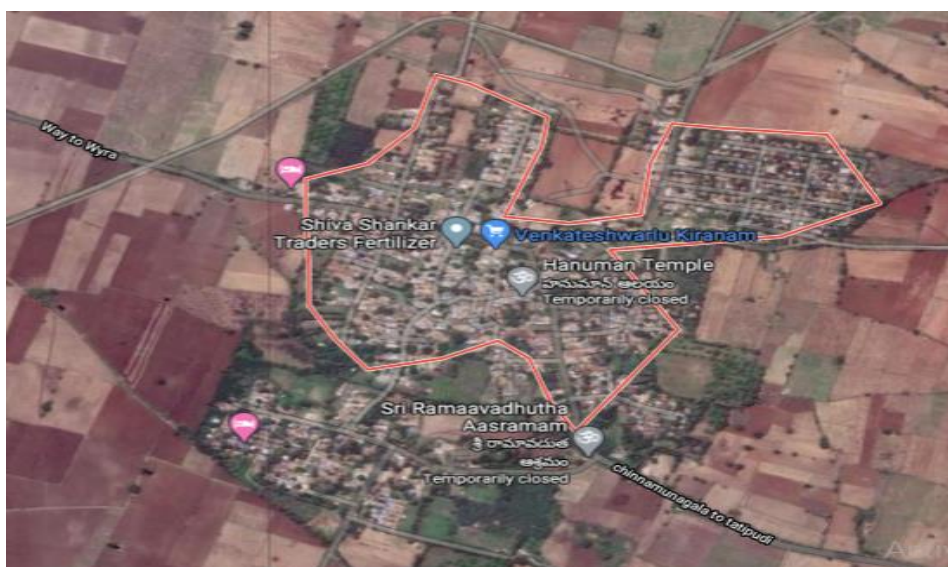

Fig.9 Google map of china munagala village

(f) Expertise available with proposed investigating group/institution for implementing project. An interdisciplinary team from different branches of engineering such as computer science, Mechanical, Civil, Electrical engineering was formed to implement this project. Artificial intelligence, mechanical and electrical machine manufacturing capabilities are there with PI and Co-PIs with these skills in house we are going to manufacture low cost machinery for producing leather products. Even we have one COPI expert from Civil to construct common facility center and to assist trainees in their micro units construction.

(g) Infrastructure available including equipment at PI's Organization.

We have advanced 3D printing lab for printing various dies to cut the leather for preparing different products. High end servers are there to run AI algorithms for detecting leather quality. Highly equipped mechanical, electrical laboratories are there for preparing machinery. Material testing labs are there to conduct research to identify composite material for manufacturing.

2. Objectives :

i. To protect Traditional knowledge and skills of artisans belongs to SC community living in china munagala village
ii. Building and Integration of state of art technology for improving traditional leather product manufacturing
iii. To establish Automated Common service Centre for product expansion and Training
Iv To promote entrepreneurship culture by enabling forward linkages
V. To integrate Ecommerce Technology to sell the produced products globally

3. Technologies (Interventions) selected for development and/or dissemination along with justification

A. Leather quality detection :

In this project we are planning to build a machine which is capable of detecting leather quality. To achieving that we are planed to implement a Deep learning framework to check the quality of the leather before start producing any products. The prototype of the planed hardware used to implement leather quality detection

Leather Cutting Machine: Traditionally people are using various instruments like knives to cut the leather as per their product requirements. In this approach they are unable to produce more products and the quality of the cutting and shape of the product also vaarying .To solve these problems we are proposing a machine which can able to perform die based cutting through hydrlic pressure generated through electrical power. The motors inside the machine convert electrical power into hydrolic force. Through this machine large number of shapes with high quality can produce in less time and effort . for shapes in our campus we are having advanced 3D printing labs there we are going to prepare different dies used in

manufacturing different products

Sole cutting Machine: Sole is important material used in many leather products; mostly it covers bottom part of the product. It is thicker than leather for cutting the sole we are proposing a low cost hydraulic machine which works in both manual as well as electrical power to generate hydraulic force. By covering the draw backs in the existing system we are planning to manufacture this machine with composite material to reduce cost and time which intern help these SC workers to produce high quality products in less time these machines definitely add more ethnic value to their traditional works.

Leather sewing machine: sewing is very important phase in manufacturing various leather products such as sandals, shoe, wallets etc. different products required different types of threads for sewing. Traditionally these workers sewing manually with small instruments it is a lot of time consuming process and required more manual power. To solve these problem we are introducing a low cost multiple sewing machine which can be used for multiple product stretching with high speed

Leather embossing machine: Ball pressing machine is used to print any design on the leather or logos any text that is made through different molds. In traditional work these kind of designs are not there in their work , in order to create more beauty to the products we are introducing a simple mechanical ball press that help to paste two items, designs on the items etc.

Leather polish detection: Polishing the leather also one of the major task in leather product manufacturing in this process we are introducing AI based machinery which will automatically stops when polishing was reached to optimal level that saves time and quality of the product when compare to manual observation of the polishing condition.

(b) Relevance of the proposed interventions to the existing Micro & Small Enterprises and Artisan Units, Industrial clusters and augmentation of proposed technologies in development of existing clusters. Till today the leather workers in this village are using traditional tools to produce leather products in below diagram we have show some of the tools.



The technologies proposed in this project will help targeted population to produce leather products with less effort when compared to usage of their traditional tools.

The ethnic value of the product will improve when they are produced through machinery

This kind of production helping them to compete in the global market that brings lot of opportunities for them.

We will provide assistance to establish manufacturing units by taking help from external bodies. So their income levels increases drastically that definitely changes socio economical condition of these SC community people.

4. Work Plan (under the following heads on separate sheets)

(a) Methodology:

In these days advanced machinery available to manufacture leather sandals, shoe, belts, bags, wallets both men and women with raw materials like goat leather, paper boar and lining cloths the products made through machinery are high in quality and attracting customers through out the globe so we are planned to introduce these machineries into their traditional work .Definitely it will help them to produce high quality products with reduced effort.

A. Leather quality detection: In this field assessing the quality of the raw material is essential before manufacturing the product. So far people are identifying quality of the leather by looking through their eyes, but majority of the cases they are unable to identify minute defected regions on the leather, finally product made with that leather getting rejected. To solve this problem we are introducing a Deep Learning technique to automatically detect defected regions. In this approach we are going to build a CNN and it is trained with various kinds of leathers which are labeled as good, defected after the training model can able to classify good leather and defected leather. The hardware used in this phase is a CC camera and a lamp through camera leather image captured and is provided as input to the model then model detects weather that piece of leather is good or defected. With this approach leather products will never get rejected due to quality issues.

B. Leather Cutting Machine:

Traditionally leather cutting was done manually using knife and other instruments,in this process the quality of the cutting is very poor. Apart from quality the speed of the work is very low. Even cutting is the very essential phase

for manufacturing any kind of leather product. So in this project we are manufacturing a hydrolic based leather cutter which will cut the leather based on the die shapes. In this we are using composite material for manufacturing leaver and external material which will come in low cost and durable when compared to existing cutting machines. The motors inside the machine convert electrical power into hydrolic force. Through this machine large number of shapes with high quality can produce in less time and effort , for shapes in our campus we are having advanced 3D printing labs there we are going to prepare different dies used in manufacturing different products.

Even this die manufacturing also automated using a software robot. It is build using robotic process automation implemented on UIPath software which help to create dies automatically without manual intervention..

C. Sole cutting Machine: Traditionally people are using various traditional methods in order to shape a sole as per the product requirement.



To avoid difficulty in traditional work we have introduced a machine which can able to cut the sole as per the given dimensions even machine can able to cut many shapes in asingle shot in different widths. After cutting upper layer is pasted to sole and by using ball press we can attach sole and leather. This machine can able to hold different kinds of blades such as stright edge blades,cross edge blades etc.

D. Leather sewing machine: Traditionally leather workers having practice of sewing products with their own hands. Definitely it is highly time consuming process due to this workers can able to produce very less number of products. In this project we are proposing a machine with clutch motor , servo motor optimized in power consumption high cycling speed and strong needle support. This machine can able to sew all types of leather products with high speed and accuracy by compensating existing problems like Fabric or threads are bunching at the start or ends of seams, Machine skipping stitches etc

E. Leather Embossing :

Beatification is very important for selling any product, in traditional days workers unable to print design, names, logos on leather products in this proposal we are introducing machinery called ball press. By using this machine we can print customized logos on leather products shown below. This machine optimized with low power liver to reduce power leaver so that effort required to apply the manual force also reduced. This machine can work with dies of different dimensions all the designs printed on the die can be transferred to leather by using ball press.



F. **Leather polish detection:** Polishing the leather also one of the major task in leather product manufacturing in this process we are introducing AI based solution which will automatically stops when polishing was reached to optimal level using deep learning. This model saves time and quality of the product when compare to manual observation of the polishing condition.

(b) Organization of work elements:

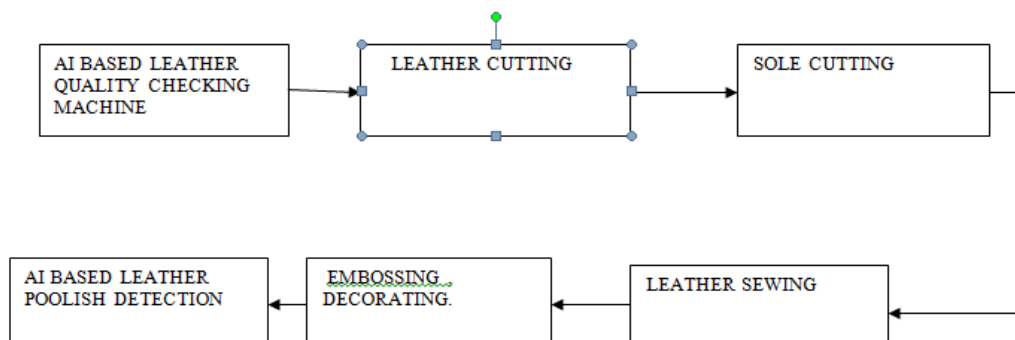

(c) Time schedule of activities giving milestones:

Sl. No	Name of Milestone	Expected Start (Month/Year)	Expected Completion (Month/Year)	Deliverables
1	Field work	1	4	Identification of place for Hub
2	Motivation Sessions	5	8	Identifying final beneficiaries
3	Basic design	9	12	Machines design completes
4	Creating Prototypes	13	18	Materializing design
5	Lab testing	19	24	Product testing in lab
6	Manufacturing	25	28	Completion of machines
7	Building online/offline marketing Channels	29	32	Building E-Commerce site
8	Establishing own Micro Enterprises	33	36	Potential beneficiaries

5. Details/Mechanism for the involvement of SC/ST Population in the project.

First we have planned to take the assistance of NGO we have associated in identifying real skilled people. We will provide various technical training sessions and practical sessions to understand how to work with machinery. Once they have trained they will be trained on entrepreneurship. Some of them are hired in common facility center to assist continuous training and production. Remaining trainees we will motivate them for establishing micro production units. Once units are established their produce will link to centrally established E-Commerce platform so that they can sell their products. Continuous training on technological improvements will be conducted to the trainees. During execution of the project they are assisted through central facility center in all the aspects of establishing units, production, marketing, troubleshooting.

6. Indicate whether the project will help in maintaining environmental/ecological balances.

There is no harm to environment with this production units

7. Details of self-employment/revenue generation through the project in long term/development of entrepreneurship (indicate the additional income per annum through this project per beneficiary/family).

Once training is completed in all aspects beneficiaries can able to start their own manufacturing units as individual households or as a group. Main achievement through this project is round the clock they will have work. They need not required to work under some one they can able get self-employment. In usual days their household income is 72,000 per annum around due to lack of work throughout the year. Due to this project a unit can earn 1500 per day means 45,000 per month 5,40,000/- per annum they can earn which is much higher revenue when compared to their previous earnings.

8. Comment on the possibilities of the activity becoming self-sustainable / marketing / buy back arrangements /Micro Enterprise Development etc (give in terms of finite time including cost benefit analysis of the project) – Techno-economic viability of the project and its self-sustainability

There are very good chances for providing buy back facility through central facility center because in the world market leather products are having highest demand. Even marketing channels can be established through this center to meet different requirements of retailers due to guaranteed purchases the established units are definitely in profit. Due to in house build low cost machinery production cost will be low and quality of the products are very high As

per the minimum expected profit statistics with in 2 years they are going to reach their break even then model turns into self sustainable

9. Trainings & Workshops

(Given details of trainings and workshops to be conducted for capacity building, deploying and dissemination of technologies for achieving the target objectives)

A regress training will be provided to the selected beneficiaries on different phases in the production. we have identified skilled trainers from CSIR- Central Leather research institute Adyar Chennai. Various phases of training conducted on leather quality checking, cutting ,sewing, embossing and polishing. Initially we are planning to select 100 members depends on their interest they are divided into 5 groups Every batch 45 days of training will be given parallel and every member we will made as full stack developer across all the phases.

10. Parameters to be used for evaluation of the impact

(Give details of Pre-intervention benchmark studies/surveys – See Annexure VII also)

Pre Intervention (Bench Mark)	Anticipated Outcome (likely deliverables)
Traditional manual tools are used	Number of new technologies/ techniques/ tools/ processes developed
No such a setup of facility center parentally they will learn the skill work informally in different places	Number of Common Facility Centres/ Permanent Structures/ Common Resources Created
Job creation not there	Number of skilled manpower (men and women) generated and jobs created
Poor quality life	Improved access to basic infrastructure facilities like Energy, Water, Health, Sanitation, Built environment etc (Number of HH)
Individual working no groups for leather workers	Number of SHGs/CIGs/TAGs/FPOs formed under the Project

11. Linkages with R&D institutions/S&T based knowledge institutions (NGOs) etc.

Tentatively formed an MoU with a ASHRITHA is a registered NGO(Regd.No.1611/12) having its registered office in #H.No.8-3-132/23 Janardhan Reddy colony, Meerpet, K.V.Ranga reddy,Telangana-500097. It is an welfare society extending services to SC/ST community people in various parts of telangana. Their prime service Moto is educating and creating awareness among SC/ST community to establish small and micro enterprises, providing information about job opportunities as per their skills.

12. Likely Impact of the Project.

b. The leather workers in this village using traditional tools
It is very difficult and time consuming process to prepare products using this tools so we are proposing various kinds of machinery such as leather quality checking machine , cutting machine, Leather Skiving machine, Ball press etc. A common center of 1200 sq. ft is established in china munagala village Khamam district, Telangana. The selected Scheduled Caste artisans are undergone for regress training on machinery at the center by domain experts so that their traditional art is modernized to the current requirements of the society so that these workers can able to improve their skills and learn how to operate machinery for different purpose. Even these machines consumes less power and space help the workers to produce goods in less time with high quality. This will generate good revenues so socio economic conditions of these people will change.

PART III: BUDGET

BUDGET ESTIMATES – SUMMARY*

<i>Sl. No</i>	<i>Item</i>	<i>Budget</i>			
		<i>1st Year</i>	<i>2nd Year</i>	<i>3rd Year</i>	<i>Total</i>
A	RECURRING				
1	Manpower	8,04,000	8,04,000	8,04,000	24,12,000
2	Consumables	3,20,000	3,20,000	3,20,000	9,60,000
3	Travel	80,000	80,000	80,000	2,40,000
4	Training Programs	3,00,000	3,00,000	3,00,000	9,00,000
5	Review Meeting by DST	20,000	20,000	20,000	60,000
6	Contingencies	55,000	55,000	55,000	1,65,000
7	Institutional Overheads	1,50,000	1,50,000	1,50,000	4,50,000
B	NON RECURRING				
1	Permanent Equipment	6,83,000			6,83,000
2	Fabrication of Equipment	1,55,000	1,00,000	1,00,000	3,55,000
3	Construction Costs	1000000			1000000
TOTAL		35,67,000	18,29,000	18,29,000	72,25,000

A. RECURRING

1. BUDGET FOR MANPOWER

<i>Sl. No.</i>	<i>Designation</i>	<i>Budget (Rs)</i>			
		<i>1st Year</i>	<i>2nd Year</i>	<i>3rd Year</i>	<i>Total</i>
1.	Project Scientist	3,60,000	3,60,000	3,60,000	10,80,000
2.	Project Associate	2,64,000	2,64,000	2,64,000	7,92,000
3.	project Assistance	1,80,000	1,80,000	1,80,000	5,40,000
	TOTAL	8,04,000	8,04,000	8,04,000	24,12,000

2. BUDGET FOR CONSUMABLES

<i>Sl. No</i>	<i>Consumables</i>	<i>Budget (Rs)</i>			
		<i>1st Year</i>	<i>2nd Year</i>	<i>3rd Year</i>	<i>Total</i>
1.	Goat leather	1,80,000	1,80,000	1,80,000	5,40,000
2.	Lining cloth	60000	60000	60000	180000
3.	Zips	20000	20000	20000	60000
4.	Buttons	10000	10000	10000	30000
5.	D or O rings	10000	10000	10000	30000
6.	Silver Polyester Eagle Industrial Threads Cones	20000	20000	20000	60000
7.	Decorative fitting	20000	20000	20000	60000
<i>TOTAL</i>		<i>3,20,000</i>	<i>3,20,000</i>	<i>3,20,000</i>	<i>9,60,000</i>

3. BUDGET FOR TRAVEL

<i>Sl. No</i>	<i>Purpose</i>	<i>Budget</i>			
		<i>1st Year</i>	<i>2nd Year</i>	<i>3rd Year</i>	<i>Total</i>
1.	Project Logistics	25,000	25,000	25,000	75,000
2.	Field Activities	55,000	55,000	55,000	1,65,000
<i>TOTAL</i>		<i>80,000</i>	<i>80,000</i>	<i>80,000</i>	<i>2,40,000</i>

4. BUDGET FOR TRAININGS

<i>Sl. No</i>	<i>Description of Trainings</i>	<i>Budget</i>			
		<i>1st Year</i>	<i>2nd Year</i>	<i>3rd Year</i>	<i>Total</i>
1.	Induction Training	30,000	-		30,000
2.	Orientation and inception of the course	20,000	-		20,000
3.	Hands on training		-	2,50,000	2,50,000
4.	Practice session	-		1,50,000	1,50,000
5.	Testing Period	-	1,50,000		1,50,000
6.	Training on End Product	-	-	3,00,000	3,00,000
<i>TOTAL</i>		<i>3,00,000</i>	<i>3,00,000</i>	<i>3,00,000</i>	<i>9,00,000</i>

5. REVIEW MEETINGS BY DST

<i>Sl. No</i>	<i>Description of Trainings</i>	<i>Budget</i>			
		<i>1st Year</i>	<i>2nd Year</i>	<i>3rd Year</i>	<i>Total</i>
1.	Review Meeting by DST	20,000	20,000	20,000	60,000
TOTAL		20,000	20,000	20,000	60,000

6. BUDGET FOR CONTINGENCIES

<i>Sl. No</i>	<i>Item</i>	<i>Budget</i>			
		<i>1st Year</i>	<i>2nd Year</i>	<i>3rd Year</i>	<i>Total</i>
1.	Documentation	15,000	15,000	15,000	45,000
2.	Service to the equipment	40,000	40,000	40,000	1,20,000
TOTAL		55,000	55,000	55,000	1,65,000

7. BUDGET FOR OVER HEADS

<i>Sl. No</i>	<i>Item</i>	<i>Budget</i>			
		<i>1st Year</i>	<i>2nd Year</i>	<i>3rd Year</i>	<i>Total</i>
1.	Institutional over heads	1,50,000	1,50,000	1,50,000	4,50,000
TOTAL		1,50,000	1,50,000	1,50,000	4,50,000

B. NON RECURRING

BUDGET FOR PERMANENT EQUIPMENT/STRUCTURES

<i>Sl. No.</i>	<i>Item</i>	<i>Budget</i>			
		<i>1st Year</i>	<i>2nd Year</i>	<i>3rd Year</i>	<i>Total</i>
1.	Equipment	6,83,000			6,83,000
2.	Fabrication Costs	1,55,000	1,00,000	1,00,000	3,55,000
3.	Construction Costs	1000000			1000000
TOTAL		18,38,000	1,00,000	1,00,000	20,38,000

PART IV: DETAILS OF THE IMPLEMENTING INSTITUTE

1. Description of the implementing agency

CMR Technical Education Society was established in the year 2007, vide **Regd. No. 1128 / 2007** under the leadership of **Sri. C. Gopal Reddy** as Chairman and **Smt. C. Vasantha Latha** as Secretary, with an aim and objective to provide quality education among the different sections of the Society through establishing institutions in the field of Science, Humanities, Fine Arts, Management and Engineering.

a. List of ongoing and completed projects during the last 10 years

<i>Sl. No.</i>	<i>Title of the project</i>	<i>Name of funding agency</i>	<i>Status (Ongoing/Completed)</i>	<i>Amount (Rs lakh)</i>
1.	International Conference on "Materials Research and Applications-ICMRA-2016"	BRNS AERB TSCOST	<i>Completed</i>	150000.00
2	UGC Raman Fellowship	UGC	<i>Completed</i>	2657844.00
3	National Conference on Computer, Security, Image Processing, Graphics, Mobility and Analytical (NCCSIGMA-2016)	SERB DST	<i>Completed</i>	100000.00
4	Metal Oxide Nanocomposites for BTEX Sensor Application	SERB DST	<i>Completed</i>	2860000.00

5	Context Vector Machine for Thematic Traits in Multimedia Files and Documents	DST	Ongoing	3773600.00
6	Assessment of R&D Impact on Socio-Economic Status of Rural India	DST	Ongoing	3655960.00
7	Second Expert Committee Meeting Biobliometrics	DST	<i>Completed</i>	1210000.00
8	Prediction of the Air Quality in Road Traffic Air-water samples by Temporal-Spatial Distribution using Foldscope	DBT	<i>Completed</i>	800000.00
9	Co-dopped ZnO thin films of toxic VOC sensing	UGC-DAE Consortium for Scientific Research	<i>Completed</i>	45000.00
10	For PG Colleges	DST	Ongoing	4500000.00
11	National Conference on Cyber Security, Image Processing, Graphics, Mobility and Analytical (NCCSIGMA-2K19)	SERB DST	<i>Completed</i>	100000.00

12	Development of Bio-Degradable Prosthetic Limbs using 3D-Printing for Moment Disability People	DST(SEED)	Ongoing	3590316.00
13	Development of Indium tin Oxide based sensors for enhanced toluene detection	JNTUH	Ongoing	250000.00
14	Development of WO ₃ based thin film sensors for medical diagnosis devices	JNTUH	Ongoing	250000.00
15	Study of stimulating research in Indian University for socio-economic development of India	DST	Ongoing	
16	International Conference on Advanced Light-weight Materials and Structures	DST SERB	COMPLETED	100000.00

b. Expertise available with the proposed investigating group/institution for implementing the project :

An interdisciplinary team from different branches of engineering such as computer science, Mechanical, Civil, Electrical engineering was formed to implement this project. Artificial intelligence, mechanical and electrical machine manufacturing capabilities are there with PI and Co-PIs with these skills in house we are going to manufacture low cost machinery for producing leather products. Even we have one COPI expert from Civil to construct common facility center and to assist trainees in their micro units construction.

c. Infrastructure available land/building .

InCMR Technical Campus huge infrastructure is available in the form of laboratory buildings, conference halls administrative buildings big auditorium, training halls and class rooms the land occupied by the institute more than 30 acers. The following are the glimpses of buildings in our campus.



We have advanced 3D printing lab for printing various dies to cut the leather for preparing different products. High end servers are there to run AI algorithms for detecting leather quality. Highly equipped mechanical, electrical laboratories are there for preparing machinery. Material testing labs are there to conduct research to identify composite material for manufacturing.

Centre for Additive Manufacturing and Product Design (CAPD) is a laboratory in the Department of Mechanical Engineering with the aim of developing and printing the products in the form of rapid and efficient prototyping as well as rapid additive manufacturing of low-volume products with high geometric creativity.

The 3D scanner, extruder for filament extrusion, three fused deposition modeling (FDM) machine and one high- temperature fused deposition modeling machine are available in our CAPD laboratory. The machine can be printed the parts by plastic based filament materials. In these machines, the maximum of 15% of metals with 85% plastic filaments can be used for 3D printing. The pure metal parts cannot be printed using the available machines in our CAPD laboratory. Selective Laser Melting (SLM) and Direct Metal Laser Sintering (DMLS) are two metal additive manufacturing processes that belong to the powder bed fusion 3D printing methods. The SLM and DMLS machines are to be purchased to strength our CAPD

laboratory. Addition of these machines will strengthen the laboratory to develop the plastic and metal based products and train the students with metal and plastics.

2. a. Type of organization:

	<i>Implementing Org.</i>	<i>Collaborator</i>
Academic Institution	yes	
Research Organization		
S&T Council		
Voluntary Organization		yes
Other (please specify)		

b. Collaboration if any, give details of institution(s)

<i>Sl. No.</i>	<i>Name of the Collaborator</i>	<i>Purpose</i>
1.	Tentatively formed an MoU with a ASHRITHA is a registered NGO(Regd.No.1611/12) having its registered office in #H.No.8-3-132/23 Janardhan Reddy colony, Meerpet, K.V.Ranga reddy,Telangana-500097.	Role: Assistance in selection of right people,To motivate the selected SC people for active participation, Coordinating with local authorities, dissemination of information,

CURRICULUM VITAE

Dr. T.S.MASTAN RAO

D.NO:7-22,

**MELLEMPUDI(POST),
TADEPALLI(MANDAL)**

Guntur -522003.

Mobile: +919000404339

Email: Mastan1061@gmail.com

CAREER OBJECTIVE:

A dignified academic professor with an established following and an in-depth knowledge in the discipline of programming; has pioneered and launched independent research programs; has a good morale standing and public record; highly interested in participating in the development of new interdisciplinary programs of study; has deep commitment to teaching; excels in research and has established a linkage with the industry.

Educational Qualifications:

- Ph.D. in C.S.E From KL University, Vijayawada, During A.Y:2017-18(March-2018) A.P.
- **M.Tech** in Computer Science and Engineering from Bharath University, Chennai during 2006-08
- **B.Tech** in Information Science and Technology from Acharya Nagarjuna University(KLCE) , during 2001-05

Teaching Experience Details :12.4 years

- Working as Assoc Prof & Head Innovation Cell in CMRTC from July-2018 to Till date
- Worked as an Assoc.Prof in KL University from Sep-2009 to July -2018
- Worked as Asst Professor in Lakki Reddy Balireddy College of Engineering June 2008-Aug-2009.

Ph.D Thesis:

“A Recommendation system for E-Commerce products based on priority Enriched Multivendor Facet Search “

International Journal Publications:

S.NO	TITLE OF THE PAPER	JOURN L	YEAR& MO NTH
1	A Model for Stock Price Predictions Using Deep Learning Techniques	IJATCSE,VOL -9,ISSUE-5	OCT-2020
2	Anovel approach to mitigate problems in E-Commerce Recommendation systems	IJAE,Volume XII, Issue VI, June/2020	JUNE-2020
3	A Software Quality Measurement using Generalized Half Logistic Distribution	IJAST, Vol. 29, No. 3, (2020), pp. 9665 - 9669	MAY-2020
4	A Frame Work For Automatic Liver Image Segmentation Using CU-Net	IJAST,Vol. 29 No. 7 (2020)	AUG-2020
5	A model to detect social network mental disorders using ai techniques.	VOL 7, ISSUE 15, 2020	JULY-2020
6	An Efficient Text-Based Image Retrieval Using Natural Language Processing (NLP) Techniques	Intelligent System Design, Springer Nature Singapore Pte Ltd. 2021	SEP-2020
7	Analytic Framework to extract knowledge from precision Agriculture data	JETIR,Vol-6,Issue-4 (UGC)	April-2019
8	Auto Encoder Based K-means Clustering Algorithm	IJITEE, (scopus)	v0l-8,Issue-05,2019,2278-3075March - 2019
9	A Novel IOT Based Expert System To Mitigate The Problems In Shrimp Culture	Jour of Adv Research in Dynamical & Control Systems, (scopus)	Vol. 10, 04-Special Issue Sep- 2018
10	A framework for generating rankings to e-commerce products based on reviews using NLP	(IJMET) (scopus) Volume 9, Issue 1,	January- 2018
11	A recommendation system for e-commerce products based on priority enriched multivendor faceted search	PONTE (scopus) Vo lu me 73 - Issue 5	May-2017
		IJPAM	Volume 117

12	Multi vendor weighted product recommendation systems	(scopus)	No. 16,573-581
13	An advanced product recommendation framework by using multiple product feature analytics	JATIT (scopus)	20th November 2015. Vol.81. No.2
14	A novel product filtering and product recommendation system to optimize the search space and sparsity in real time ecommerce environment	JATIT (scopus)	20th November 2015. Vol.81. No.2
15	A Review Paper on Recommender Systems To optimize Search Space and Sparsity In E-Commerce Environment	IJAER (scopus)	Volume 10, Number 8 (2015)
16	Ontology Based Fuzzy Rule Mining Technique for Web usage Analysis	IJAER (scopus)	Volume 9, 2014
17	Hybrid Model for Pre-processing and Clustering of Web Server Log	IJCAES	Vol-3, Issue-1 Mar-13
18	An effective frame work for identifying PRS using web usage mining	IJERA	May – June-12 volume-2 issue-3
19	Web Usage Mining on Cluster Architecture	GJCAT	Vol-2., issue-1 Feb-12
20	An Enhanced Framework For Performing Pre-Processing On Web Server Logs	IJETT	Vol -3., Issue-2 Apr-12
21	Simultaneous Data Compression and Encryption	IJCSIT	Vo l:02, Issue:05, sep2011
22	Framework for Testing Web Applications using Selenium Testing tool with respect to Integration Testing	IJCST	Vo l:02, Issue:03 Sep, 2011
23	Performance Evaluation Methodology for Biometric Authentication	IJCST	Vol:02, Issue:03 Sep, 2011
24	An advanced multi level pre processing on web server logs	GJCAT	Vol-3(4),2013

Patents:

- 1) **Title of the invention :** A System For Ranking Products Across E-Commerce Sites Based On Weighted Facet Search Along With Validated Reviews, Application No.201841042350 A. Nov-2018
- 2) **Title of the invention :**System for detecting diseases in plants Application No.201941011100A, March-2019
- 3) **Title of the invention:** A Deep Learning Model for student future prediction Application No.201941020783A, June -2019
- 4) **Title of the invention:** Deep learning model for image fraud Detection Application No.201941032618A Aug-2019

Text Books:

Recommendation System for E-Commerce products based on faceted search, 978-613-9-46411-1.

Guest Lectures:

- Guest lecture on Machine Learning using python in VKR engineering College Gudivada on 30-08-2019.
- Guest Lecture on Machine learning at Loyola Engineering College on 24th July - 2019.

ADMINISTRATIVE DUTIES:

- 1) Head innovation Cell CMRTC, Hyderabad.2019 Aug to Till Date.
- 2) SPOC SIH at CMRTC 2018 July to till date
- 3) Head AI Research Group at CMRTC 2018 Aug to till date.
- 4) Head placement Training KLEF 2011 March - 2018 June.
- 5) Zensar Virtual industry Coordinator, 2010-2012.
- 6) Alumni Cell head CSE Department KLEF, 2017 to 2018.
- 7) Exam Section Incharge CSE Department.2012-2014.
- 8) NAAC,NBA,NIRF Core committee member.2014-2018.

EVENTS ORGANIZED:

1. One Week Faculty Development Program on “AI & Machine Learning” December 23-27, 2019, Sponsored by MeitY, Govt of India.
2. One Week Faculty Development Program on “Deep Learning and Applications” December 9-13, 2019, Sponsored by MeitY, Govt of India.
3. One Week Faculty Development Program on “Python Programming with Industry Perspective” December 2-6, 2019, Sponsored by MeitY, Govt of India.

4. Organised an international Symposium on Computational Intelligence(ISCI-2K19) at CMR Technical Campus, Co-Located 6Th International Conference on Information System Design and Intelligence Applications(INDIA-2019)
5. Organized two day workshop on “Data Mining & Applications” October 22-23, 2019 at CMR Technical Campus.
6. Organized Guest Lecture on “INNOVATION, INCUBATION and ENTERPRENUSHIP” on October 15, 2019 at CMR Technical Campus.
7. Organizing Hackathon “TECHNOVANZA HACKATHON-2020”, January 9-10, 2020.
8. Nominated as the SPOC for SIH(Smart India Hackathon)-2019 from CMR Technical Campus.

WORKSHOPS ATTENDED:

- 1) One Week Faculty Development Program on “AI & Machine Learning” December 23-27, 2019, Sponsored by MeitY, Govt of India.
- 2) One Week Faculty Development Program on “Deep Learning and Applications” December 9-13, 2019, Sponsored by MeitY, Govt of India.
- 3) One Week Faculty Development Program on “Python Programming with Industry Perspective” December 2-6, 2019, Sponsored by MeitY, Govt of India.
- 4) Innovative and effective methods of Teaching & Learning Strategies at CMRTC on 13th May-17th May, 2019
- 5) Attended international Conference on Transformations in engineering Education on 7th & 8th January 2019.
- 6) Attended workshop on Human Values at KL University in June, 2014.
- 7) Attended workshop on “Sciento-metric Tools and Techniques for Research Analysis” at KL University in September, 2014.
- 8) Attended workshop on “Digital Forensics” at KL University in September, 2014.
- 9) Attended AICTE sponsored National Workshop on Research Methodology at KL University in 2013.
- 10) Attended workshop on “ How to Write Secure Code” at KL University in association with OWASP.
- 11) Attended workshop on “Object Oriented Analysis & Design using UML with Essentials of Rational Essentials of Rational Software Architect” at KL University in March, 2012.
- 12) Attended workshop on “BIG DATA ANALYTICS ” at KL University in 2014.
- 13) Attended Faculty Development Programme on “Soft Skills” at KL University in April, 2011.

- 14) Attended National workshop on ANDROID at KL University organized by CSI&KMS, March 2011.
- 15) Attended Seminar on “Cloud Computing”, at KL University, January 2011.
- 16) Attended workshop on “COMPUTER NETWORKS” at KIITS University, Bhubaneswar, Conducted by IUCEE in July, 2010.
- 17) Attended workshop on virtual industry programs , Conducted by Zensar Technologies Pune.

Achievements:

- Completed IBM Rational Functional Tester Certification (**RFT**).
- Completed IBM Rational Application Developer Certification (**RAD**).
- Best Teacher Award in 2014-15 in K I university.
- Board of Studies Member in C.S.E Department.
- Life member in computer society of india(CSI)
- Acted as a mentor for virtual industry program with ZENSAR TECHNOLOGIES in 2011.
- Vast Experience in conducting internal Examinations as a Dept Examination section in charge.
- 2 years experience in teaching DB2 and oracle certification courses.
- Submitted project proposals to various external funding agencies.

Research Interests

- Big Data Analytics
- IOT
- Data Mining
- Data science and machine learning

Subjects Handled:

- DWH
- Machine learning
- AI

- Python
- Ecommerce.
- Distributed Systems.
- Big Data Analytics
- Cloud Computing
- Database Management Systems
- Data mining.
- Software Testing

Strengths:

- Placement process management(Technical)
 - Good at innovative thinking.
-
- ✓ Research Guidance
 - ✓ Teaching Experience at U.G(B.Tech) and P.G(M.Tech) levels.
 - ✓ Innovative thinking.
 - ✓ Excellent in project Proposal writing.
 - ✓ Great Analytical Ability.
 - ✓ Good Communication Skills.
 - ✓ Positive Attitude.
 - ✓ Social Responsibility.

Personal Profile:

Name : Dr. T.S.Mastan Rao

Father's Name : Chandraiah

Gender : Male

Languages Known : English, Hindi, Telugu, Tamil, and Urdu.

Nationality : Indian

Permanent Address : **D.NO:7-22,
Mellempudi(post),
Tadepalli(mandal)
Guntur -522003.**

I hereby declare that the statements & details given by me are true to the best of my knowledge.

(Dr. T.S.MASTAN RAO)

CERTIFICATE FROM THE INVESTIGATOR

PROJECT TITLE: An AI enabled low Cost mechanized manufacturing of leather products Hub to empower SC community

1. We agree to abide by the terms and conditions of the DST grant.
2. We did not submit this or a similar project proposal elsewhere for financial support.
3. We have explored and ensured that equipment and basic facilities will actually be available as and when required for the purpose of the project. We shall not request financial support under this project, for procurement of these items.
4. We undertake that spare time on permanent equipment will be made available to other users.
5. We have enclosed the following materials:

ITEMS	NUMBER OF COPIES
(a) Endorsement from the Head of the Institution (on letter head)	One
(b) Certificate from Investigator	One
(c) Certificate from Investigator regarding conflict of interest	One
(d) Name and address of experts/institution interested in the subject/ outcome of the project	One
(e) Copies of the proposals	One hard Copy

Date : 28-10-2020

Place:kandlakoy

Name & Signature of
Principal Investigator

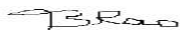

Dr.T.Subha Mastan Rao

Name & Signature Of
Co-Investigator(s)



Dr.D.Maneiah



Dr.S.Vijaya Bhaskar Reddy

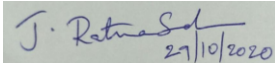

Mr.J.Ratna Babu

DEPARTMENT OF SCIENCE AND TECHNOLOGY
POLICY ON CONFLICT OF INTEREST

APPLICANT

Issues of Conflicts of Interest and ethics in scientific research and research management have assumed greater prominence, given the larger share of Government funding in the country's R & D scenario. The following policy pertaining to general aspects of Conflicts of Interest and code of ethics, are objective measures that is intended to protect the integrity of the decision making processes and minimize biasness. The policy aims to sustain transparency, increase accountability in funding mechanisms and provide assurance to the general public that processes followed in award of grants are fair and non-discriminatory. The Policy aims to avoid all forms of bias by following a system that is fair, transparent and free from all influence/ unprejudiced dealings, prior to, during and subsequent to the currency of the programme to be entered into with a view to enable public to abstain from bribing or any corrupt practice in order to secure the award by providing assurance to them that their competitors will also refrain from bribing and other corrupt practice and the decision makers will commit to prevent corruption, in any form, by their officials by following transparent procedures. This will also ensure a global acceptance of the decision making process adopted by DST.

Definition of Conflict of Interest:

Conflict of Interest means "any interest which could significantly prejudice an individual's objectivity in the decision making process, thereby creating an unfair competitive advantage for the individual or to the organization which he/she represents". The Conflict of Interest also encompasses situations where an individual, in contravention to the accepted norms and ethics, could exploit his/her obligatory duties for personal benefits.

1. Coverage of the Policy:

- a) The provisions of the policy shall be followed by persons applying for and receiving funding from DST, Reviewers of the proposal and Members of Expert Committees and Programme Advisory Committees. The provisions of the policy will also be applicable on all individuals including Officers of DST connected directly or indirectly or through intermediaries and Committees involved in evaluation of proposals and subsequent decision making process.
- b) This policy aims to minimize aspects that may constitute actual Conflict of Interests, apparent Conflict of Interests and potential Conflict of Interests in the funding mechanisms that are presently being operated by DST. The policy also aims to cover, although not limited to, Conflict of interests that are Financial (gains from the outcomes of the proposal or award), Personal (association of relative / Family members) and Institutional (Colleagues, Collaborators, Employer, persons associated in a professional career of an individual such as Ph.D. supervisor etc.)

2. Specifications as to what constitutes Conflict of Interest.

Any of the following specifications (non-exhaustive list) imply Conflict of Interest if,

- (i) Due to any reason by which the Reviewer/Committee Member cannot deliver fair and objective assessment of the proposal.
- (ii) The applicant is a directly relative# or family member (including but not limited to spouse, child, sibling, parent) or personal friend of the individual involved in the decision making process or alternatively, if any relative of an Officer directly involved in any decision making process / has influenced interest/ stake in the applicant's form etc..
- (iii) The applicant for the grant/award is an employee or employer of an individual involved in the process as a Reviewer or Committee Member; or if the applicant to the grant/award has had an employer-employee relationship in the past three years with that individual.
- (iv) The applicant to the grant/award belongs to the same Department as that of the Reviewer/Committee Member.
- (v) The Reviewer/Committee Member is a Head of an Organization from where the applicant is employed.
- (vi) The Reviewer /Committee Member is or was, associated in the professional career of the applicant (such as Ph.D. supervisor, Mentor, present Collaborator etc.)
- (vii) The Reviewer/Committee Member is involved in the preparation of the research proposal submitted by the applicant.
- (viii) The applicant has joint research publications with the Reviewer/Committee Member in the last three years.
- (ix) The applicant/Reviewer/Committee Member, in contravention to the accepted norms and ethics followed in scientific research has a direct/indirect financial interest in the outcomes of the proposal.
- (x) The Reviewer/Committee Member stands to gain personally should the submitted proposal be accepted or rejected.

The Term "Relative" for this purpose would be referred in section 6 of Companies Act , 1956.

3. **Regulation:**

The DST shall strive to avoid conflict of interest in its funding mechanisms to the maximum extent possible. Self-regulatory mode is however recommended for stake holders involved in scientific research and research management, on issues pertaining to Conflict of Interest and scientific ethics. Any disclosure pertaining to the same must be made voluntarily by the applicant/Reviewer/Committee Member.

4. **Confidentiality:**

The Reviewers and the Members of the Committee shall safeguard the confidentiality of all discussions and decisions taken during the process and shall refrain from discussing the same with any applicant or a third party, unless the Committee recommends otherwise and records for doing so.

5. **Code of Conduct**

5.1 **To be followed by Reviewers/Committee Members:**

- (a) All reviewers shall submit a conflict of interest statement, declaring the presence or absence of any form of conflict of interest.
- (b) The reviewers shall refrain from evaluating the proposals if the conflict of interest is established or if it is apparent.
- (c) All discussions and decisions pertaining to conflict of interest shall be recorded in the minutes of the meeting.
- (d) The Chairman of the Committee shall decide on all aspects pertaining to conflict of interests.
- (e) The Chairman of the Committee shall request that all members disclose if they have any conflict of interest in the items of the agenda scheduled for discussion.
- (f) The Committee Members shall refrain from participating in the decision making process and leave the room with respect to the specific item where the conflict of interest is established or is apparent.
- (g) If the Chairman himself/herself has conflict of interest, the Committee may choose a Chairman from among the remaining members, and the decision shall be made in consultation with Member Secretary of the Committee.
- (h) It is expected that a Committee member including the Chair-person will not seek funding from a Committee in which he/she is a member. If any member applies for grant, such proposals will be evaluated separately outside the Committee in which he/she is a member.

5.2 **✓ To be followed by the Applicant to the Grant/Award:**

- (a) The applicant must refrain from suggesting referees with potential Conflict of Interest that may arise due to the factors mentioned in the specifications described above in Point No. 2.
- (b) The applicant may mention the names of individuals to whom the submitted proposal should not be sent for refereeing, clearly indicating the reasons for the same.

5.3 **To be followed by the Officers dealing with Programs in DST:**

While it is mandatory for the program officers to maintain confidentiality as detailed in point no. 6 above, they should declare, in advance, if they are dealing with grant applications of a relative or family member (including but not limited to spouse, child, sibling, parent) or thesis/ post-doctoral mentor or stands to benefit financially if the applicant proposal is funded. In such cases, DST will allot the grant applications to the other program officer.

6. **Sanction for violation**

3.1 **For a) Reviewers / Committee Members and b) Applicant**

Any breach of the code of conduct will invite action as decided by the Committee.

3.2 **For Officers dealing with Program in DST**

Any breach of the code of conduct will invite action under present provision of CCS (conduct Rules), 1964.

7. **Final Appellate authority:**

Secretary, DST shall be the appellate authority in issues pertaining to conflict of interest and issues concerning the decision making process. The decision of Secretary, DST in these issues shall be final and binding.

8. **Declaration**

I have read the above "Policy on Conflict of Interest" of the DST applicable to the Applicant agree to abide by provisions thereof.

I hereby declare that I have no conflict of interest of any form pertaining to the proposed grant

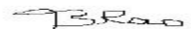

29/10/2020

Applicant

Dr.T.S.Mastan Rao

ENDORSEMENT FROM THE HEAD OF INSTITUTION

PROJECT TITLE: An AI enabled low Cost mechanized manufacturing of leather products
Hub to empower SC community.

1. Certified that the Institute welcomes participation of Dr. TUMMAPUDI SUBHA MASTAN RAO as the Principal Investigator and Dr. D. MANEIAH, Dr. S. VIJAYA BHASKAR REDDY, Mr. J. RATNA BABU as the Co-Investigators for the project and that in the unforeseen event of discontinuance by the Principal Investigator, the Co-Investigator will assume the responsibility for the fruitful completion of the project (after obtaining consent in advance from DST).
2. Certified that the equipment, other basic facilities and such other administrative facilities as per terms and conditions of the grant, will be extended to investigator (s) throughout the duration of the project.
3. Institute assures financial and other managerial responsibilities of the project.
4. Certified that the organization has never been blacklisted by any department of the State Government or Central Government.

Name and Signature of Head of Institution



Dr. A. RAJI REDDY
Director

Date: 29/10/2020

CMR Technical Campus
Kandlakoya (V), Medchal Road,
Hyderabad, Telangana - 501401.

Place: Hyderabad



Respected sir,

We are planning to develop all the machinery required in house through our project team so we need to purchase some parts and some other parts required we can print through our 3D printer so at this point we are unable to submit quotations in due course before presentation we will submit, please accept my request

Thanking you sir,

PI,

Dr.T.Subha mastan Rao.